

4.4W防破音超低功耗单声道D类音频功率放大器

4.4W Anti-Clipping Ultra Low Consumption Mono Class D Audio Power Amplifier

FEATURES

- Power Supply VDD: 2.5-6V;
- Low Quiescent Current: 0.9mA @ VDD = 3.7V(ACF OFF)
- Low Output Noise: 80uV @ 26dB
- Low Pop Noise, <2mV DC offset
- Output Power
1.5W (VDD=3.7V, RL=4Ω, THD+N=10%)
4.4W (VDD=6.0V, RL=4Ω, THD+N=10%)
- THD+N= 0.03% (Po=1W, RL=4Ω, VDD = 3.7V)
- Max Gain: 27dBV
- Anti-Clipping Function, ACF
- Over Current Protection and Thermal Protection with Auto Recovery
- Low voltage malfunction prevention function included
- Pb-Free Packages, DFN2×2-8L,MSOP8
- 电源供电 : VDD 2.5-6V;
- 低静态电流 : 0.9mA @ VDD = 3.7V(ACF OFF)
- 低输出噪声 : 80uV @ 26dB
- 低pop声, DC失调<2mV
- 输出功率
1.5W (VDD=3.7V, RL=4Ω, THD+N=10%)
4.4W (VDD=6.0V, RL=4Ω, THD+N=10%)
- THD+N= 0.03% (Po=1W, RL=4Ω, VDD = 3.7V)
- 最大增益 : 27dBV
- 防破音功能ACF
- 过流保护及自动恢复功能, 过热保护功能, 欠压异常保护功能
- DFN2×2-8L,MSOP8封装

APPLICATIONS

- OWS and other earphone devices
- smart watch · smart band
- smart glasses · smart toy
- speakers
- OWS耳机或其他耳机设备
- 智能手表
- 智能手环 · 智能眼镜 · 智能玩具
- 音箱

DESCRIPTION

The HTA6861 is an low-EMI, mono Class D audio amplifier that drives up to continuous 4.4W into 4ohm speaker with 6V power supply, and 1.5W into 4ohm speaker with 3.7V power supply.

The HTA6861 features ultra-low quiescent current of 0.9mA at 3.7V and low noise of 77μV at 26dB. HTA6861 also integrates ACF and spread spectrum function. The gain of the amplifier is max 27dBV.

The Device is available in DFN2X2-8L and MSOP8 package.

HTA6861是一款低EMI单声道输出D类音频功率放大器。其在6V供电时可提供最大4.4W的输出功率; 在3.7V供电时可提供最大1.5W的输出功率。

HTA6861具有超低静态电流, 0.9mA@3.7v; 具有超低噪声, 80uv@26db。

HTA6861还具有防破音、扩频等功能。HTA6861内置27dBV最大增益。

该产品提供DFN2X2-8L和MSOP8封装。

■ TYPICAL APPLICATION

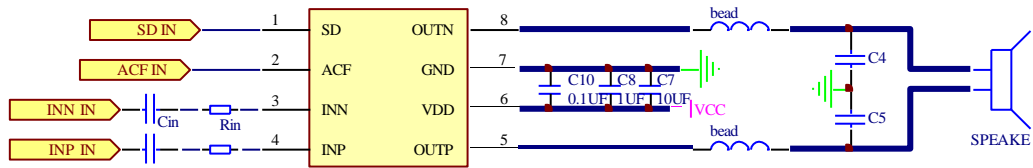

1. SD 脚设置芯片的工作模式

SDpin	工作模式
>0.9V	Class D, Work On
<0.5V	Shutdown

2. ACF 防破音管脚设置

ACF pin	工作模式	ACF管脚电压范围	说明
GND	ACF2	$0 -- \frac{1}{8}VDD$	防破音音量中等
VDD	Mute	$\frac{2}{8}VDD -- VDD$	芯片静音
100k to VDD	ACF3	$\frac{5}{8}VDD -- \frac{7}{8}VDD$	防破音音量最大
NC	ACF-OFF	$\frac{3}{8}VDD -- \frac{5}{8}VDD$	防破音关闭
100k to GND	ACF1	$\frac{1}{8}VDD -- \frac{3}{8}VDD$	防破音音量最小

3. $AV = 260k / (11k + Rin)$, Rin 为外部输入电阻。

4. 辐射和传导是关注项时，输出建议预留磁珠和电容

5. VDD 电容：一般的，为保证低频的功率，靠近VDD 管脚处 0.1uF//10uF 陶瓷电容，如需要更好滤波，可额外增加铝电解电容。

ORDERING INFORMATION

Part Number	Package Type	Package Abbr.	Marking	Shipping Package / MOQ
HTA6861DNER	DFN2x2-8L	DNE	HTA6861 YYYMAAB ¹	Tape and Reel (R) / 3000pcs
HTA6861MSNR	MSOP8L	MSN	HTA6861 YYYMAAB	Tape and Reel (R) / 5000pcs

Part Number

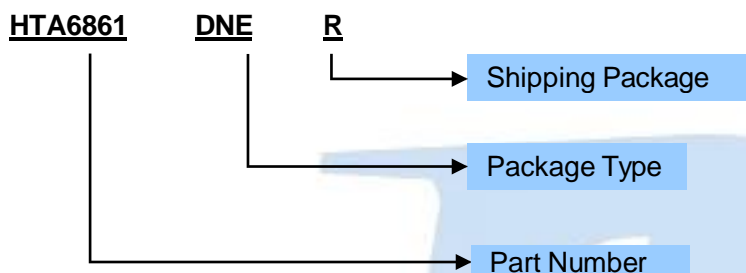

Production Tracking Code

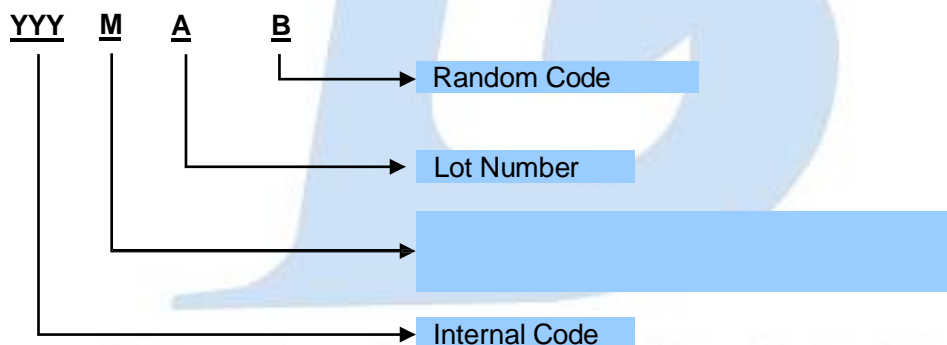

佰泰盛世
BAITAISHENGSHI

¹ YYYMAAB is production tracking code

■ TERMINAL CONFIGURATION

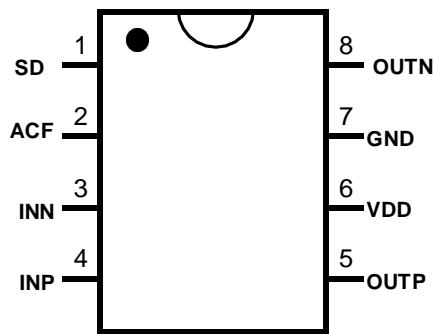

Top View

HTA6861MSN(MSOP8L)

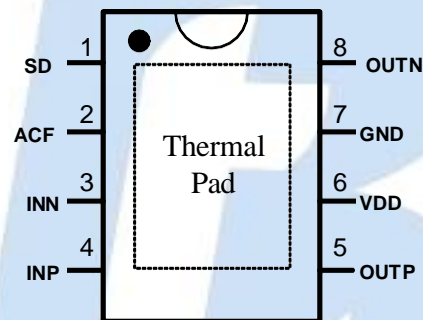

Top View

HT6861DNE(DFN8L)

■ TERMINAL FUNCTION

Terminal No.	Name	I/O ¹	Description
1	SD	I	Shutdown control terminal. 关断模式控制端,低电平芯片关断
2	ACF	A	ACF selection防破音功能选择
3	INN	A	Negative input terminal. 反相输入端
4	INP	A	Positive input terminal. 同相输入端
5	OUTP	O	Positive output terminal. 同相输出端
6	VDD	Power	Power supply.电源输入
7	GND	GND	Ground.地
8	OUTN	O	Negative output terminal.反相输出端
0			底部裸焊盘建议接地

¹I: Input; O: Output; A: Analog Terminal

SPECIFICATIONS¹
Absolute Maximum Ratings²

PARAMETER	Symbol	MIN	TYP	Max.	Unit
Power supply terminal voltage range	V _{DD}	-0.3		6.5	V
Input terminal voltage range	V _{IN}	-0.3		V _{DD} +0.3	V
Operating Ambient Temperature	T _A	-40		85	°C
Junction Temperature	T _J	-40		150	°C
Storage Temperature	T _{STG}	-50		150	°C

Recommended Operating Conditions

PARAMETER	Symbol	CONDITION	MIN	TYP	MAX	UNIT
Power Supply Voltage	V _{DD}		2.5		6	V
Speaker Impedance	R _L			4		Ω

DC Characteristics

V_{DD}=2.5V~5.5V, T_a= -40°C~85°C, unless otherwise specified.

Item	Symbol	Conditions	Min.	Typ.	Max.	Unit
VDD power supply start-up threshold voltage	V _{VVLH}			2		V
VDD power supply shut-down threshold voltage	V _{VVLL}			1.9		V
SD mode threshold voltage for terminal SD	V _{SD_L}		0		0.50	V
WORK mode threshold voltage for terminal SD	V _{SD_H}		0.9		V _{DD}	V
Quiescent current	I _{DD}	V _{DD} =3.6V, ACF-OFF		0.9		mA
		V _{DD} =3.6V, ACF-ON		1		
		V _{DD} =5.0V, ACF-OFF		1.2		
		V _{DD} =5.0V, ACF-ON		1.3		
Consumption current in shutdown mode	I _{SD}	SD=0V, T _a =25°C		0.01	0.1	μA
Over temperature protection	OTP			150		°C
Over current protection	OCP			3		A

佰泰盛世
BAITAISHENGSHI

¹Depending on parts and PCB layout, characteristics may be changed.

²Stresses beyond those listed under absolute maximum ratings may cause permanent damage to the device. These are stress ratings only, and functional operation of the device at these or any other conditions beyond those indicated under recommended operating conditions is not implied. Exposure to absolute-maximum-rated conditions for extended periods may affect device reliability.

● Analog Characteristics
 $V_{DD}=5V$, $T_a=25^{\circ}C$, $C_{IN}=1\mu F$, $ACF=NC$, unless otherwise specified.

Item	Symbol	Conditions	Min.	Typ.	Max.	Unit
Output Power	P_O	$R_L=4\Omega$, $V_{DD}=3.6V$		1.2		W
		$R_L=4\Omega$, $V_{DD}=5.0V$	$f=1kHz$, $THD+N=1\%$	2.4		
		$R_L=8\Omega$, $V_{DD}=3.6V$		0.7		
		$R_L=8\Omega$, $V_{DD}=5.0V$		1.3		
		$R_L=4\Omega$, $V_{DD}=3.6V$	$f=1kHz$, $THD+N=10\%$	1.5		
		$R_L=4\Omega$, $V_{DD}=5.0V$		3.0		
		$R_L=8\Omega$, $V_{DD}=3.6V$		0.85		
		$R_L=8\Omega$, $V_{DD}=5.0V$		1.7		
Total Harmonic Distortion plus Noise (BW: 20kHz)	THD+N	$R_L=4\Omega$, $P_O=1W$, $f=1kHz$		0.03		%
Output Noise	V_N	27dB, $f=20Hz\sim 20kHz$, A加权		90		μV_{rms}
		26dB, $f=20Hz\sim 20kHz$, A加权		80		μV_{rms}
		12dB, $f=20Hz\sim 20kHz$, A加权		30		μV_{rms}
Signal /Noise Ratio	SNR	A-Filter, $A_v=12dB$, $THD+N = 1\%$		100		dB
Power Supply Rejection ratio	PSRR	$f=1kHz$		-70		dB
Efficiency	η	$R_L=4\Omega+22\mu H$, $THD+N = 1\%$		84		%
		$R_L=8\Omega+22\mu H$, $THD+N = 1\%$		91		%
Output Offset Voltage	V_{OS}				± 2	mV
System Gain	A_{V0}	$R_{in}=0k$		27		dB

● AC Characteristics
 $V_{DD}=2.5$ to $5.5V$, $T_a=-40^{\circ}C\sim 85^{\circ}C$, unless otherwise specified.

Item	Symbol	Conditions	Min.	Typ.	Max.	Unit
Start-up time (or wake up from shutdown mode)	t_{STUP}			220		ms
Carrier clock frequency	f_{PWM}			300		KHz

佰泰盛世
BAITAISHENGSHI

TYPICAL OPERATING CHARACTERISTICS

VDD = 5V, $f_{IN} = 1\text{kHz}$, Load = 4ohm, unless otherwise specified.

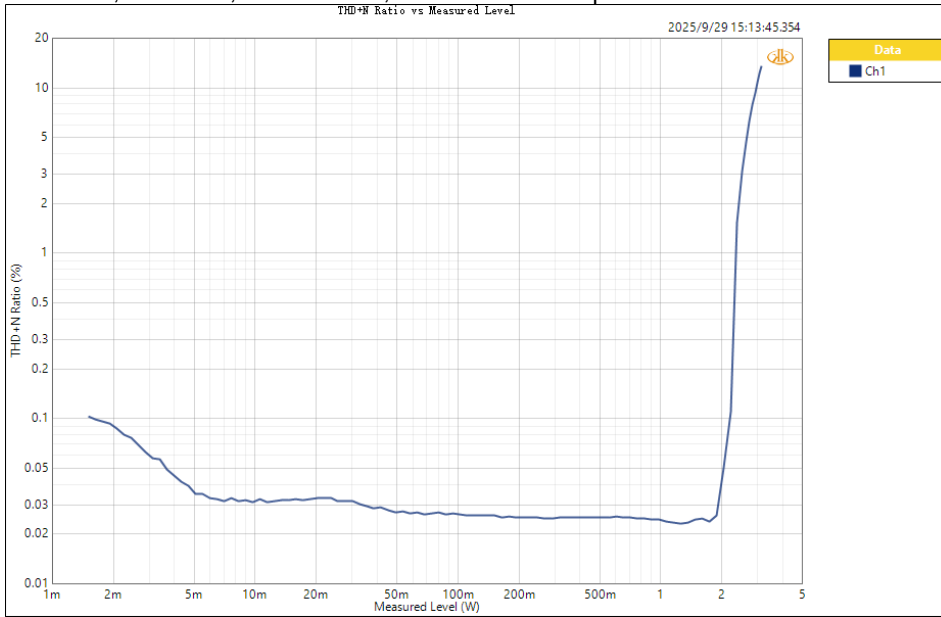

Output power vs THD+N, $f = 1\text{kHz}$

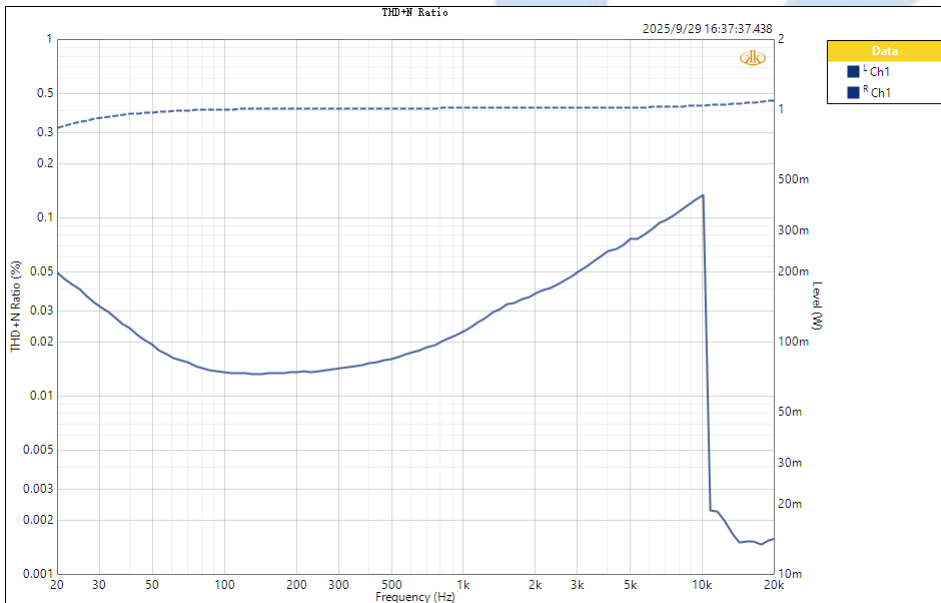

f_{IN} vs THD+N, $P_o \approx 1\text{W}$

佰泰盛世
BAITAISHENGSHI

P_O vs η

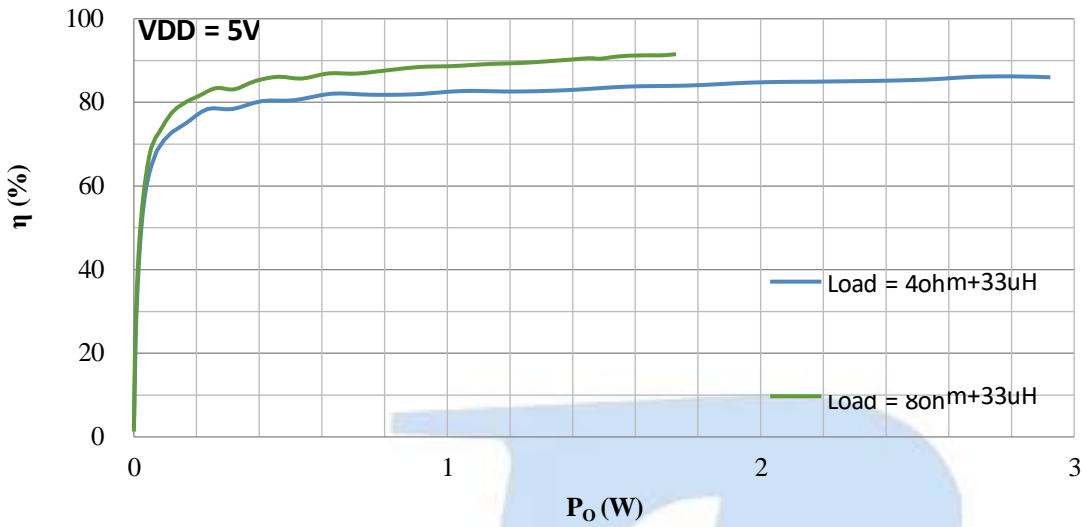

P_O vs η

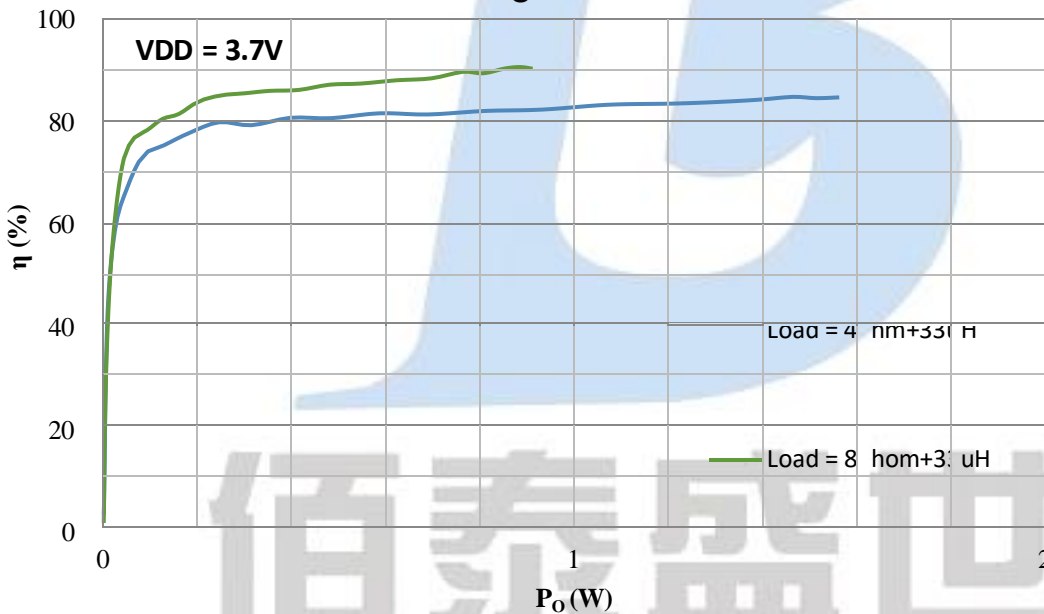

佰泰盛世
BAITAISHENGSHI

P_o vs VDD

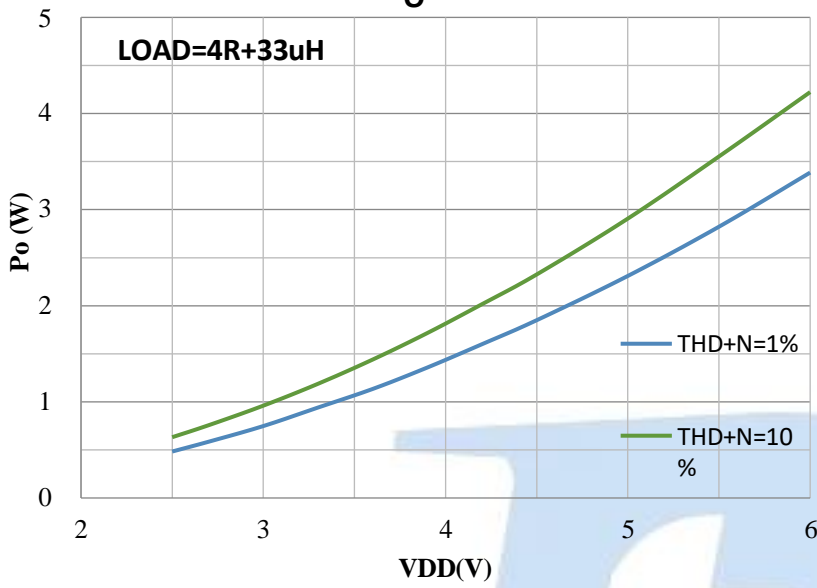

I_Q vs VDD

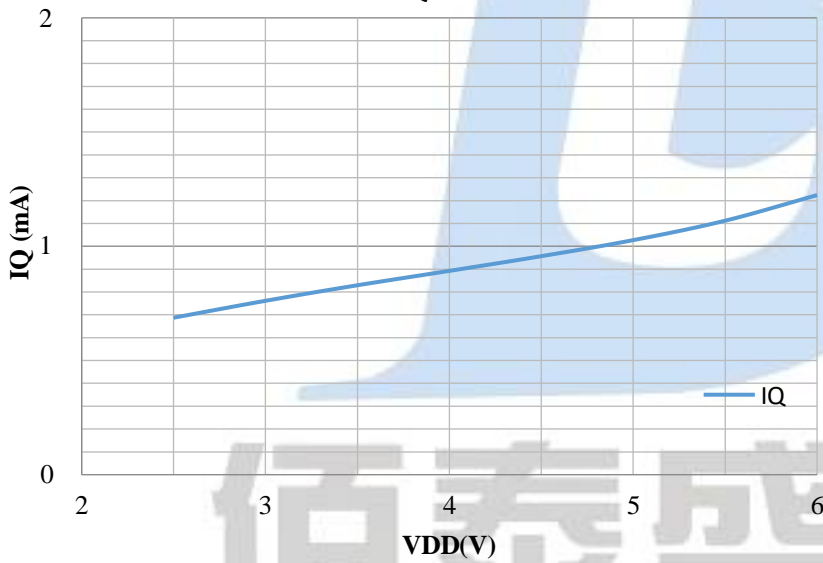

I_{SD} vs VDD

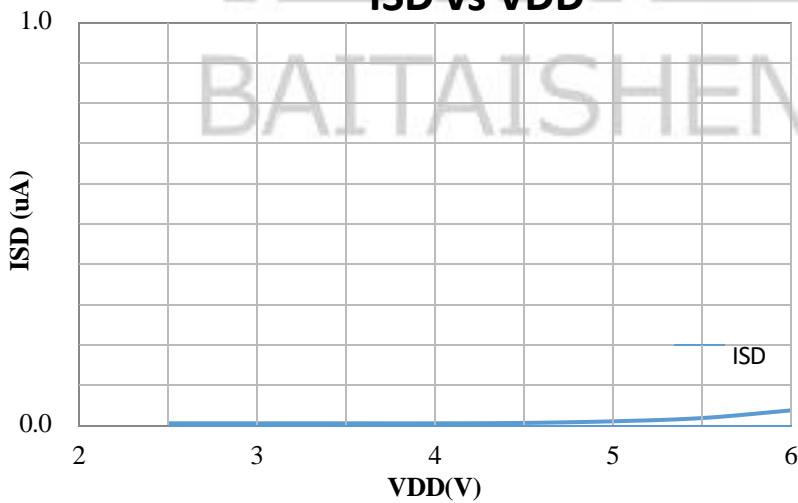

● DFN8L (HTA6861DNE)

TOP VIEW
正视图

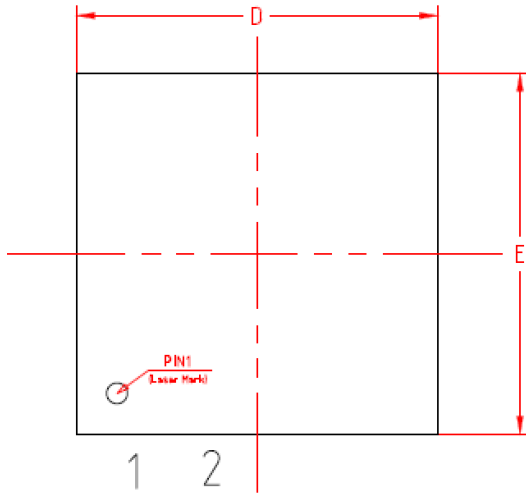

SIDE VIEW
侧视图

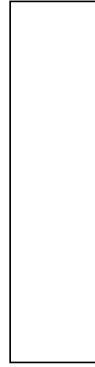

BOTTOM VIEW
背视图

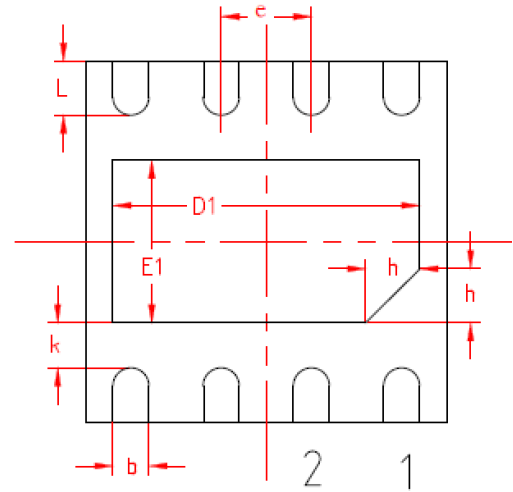

SIDE VIEW
侧视图

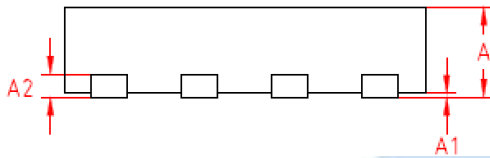

机械尺寸/mm			
字符	最小值	典型值	最大值
A	0.45	0.50	0.55
A1	-	0.02	0.05
A2	0.127 REF		
b	0.15	0.20	0.25
D	1.90	2.00	2.10
D1	1.65	1.7	1.75
E	1.90	2.00	2.10
E1	0.85	0.9	0.95
e	0.500 BSC		
k	0.20	0.25	0.30
L	0.25	0.30	0.40
h	0.25	0.30	0.35

世
SHENGSHI

● MSOP8L (HTA6861MSN)

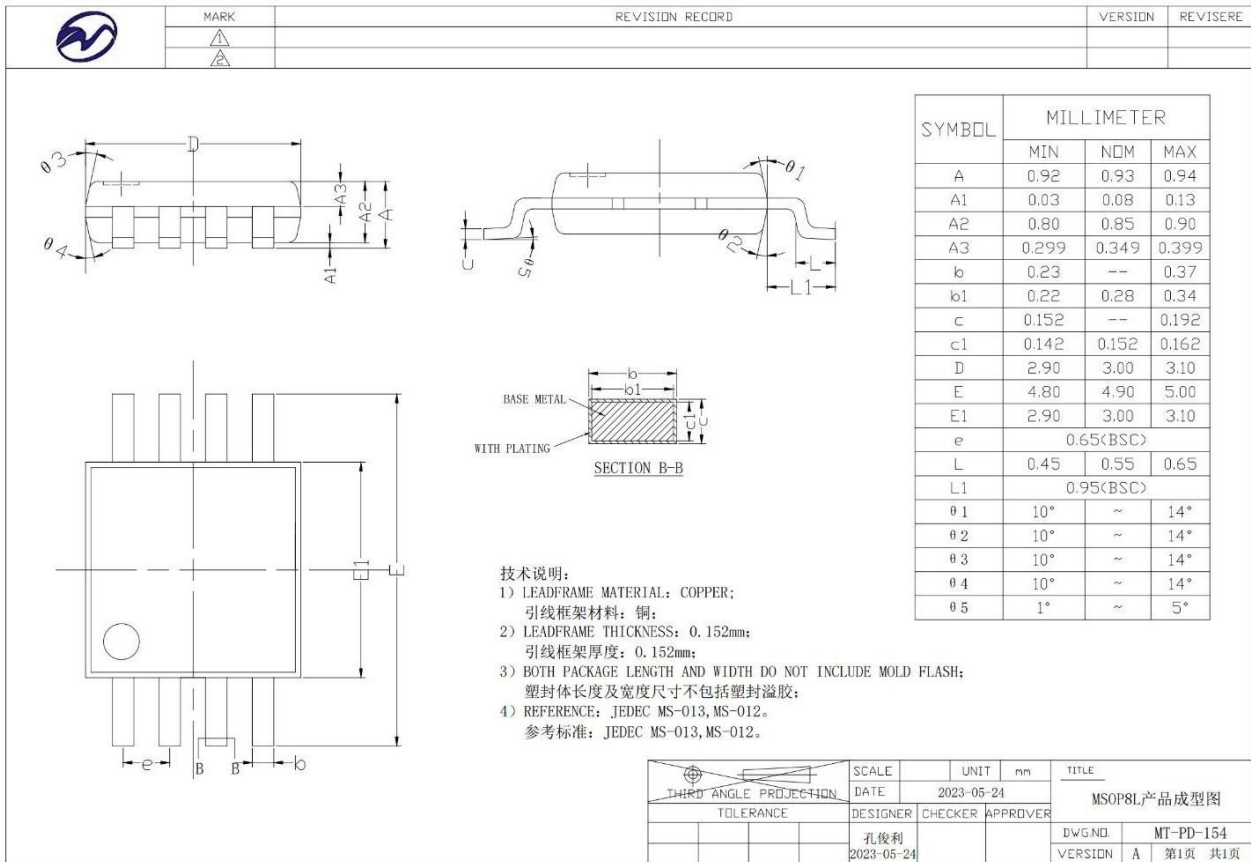

SYMBOL	MILLIMETER		
	MIN	NOM	MAX
A	—	—	1.10
A1	0.05	—	0.15
A2	0.75	0.85	0.95
A3	0.30	0.35	0.40
b	0.28	—	0.36
b1	0.27	0.30	0.33
c	0.15	—	0.19
c1	0.14	0.15	0.16
D	2.90	3.00	3.10
E	4.70	4.90	5.10
E1	2.90	3.00	3.10
e	0.65BSC		
L	0.40	—	0.70
L1	0.95REF		
θ	0	—	8°

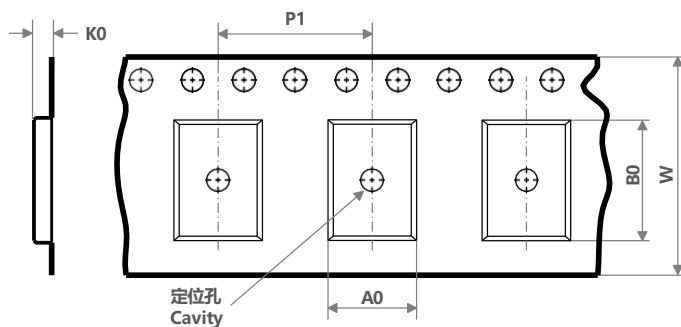
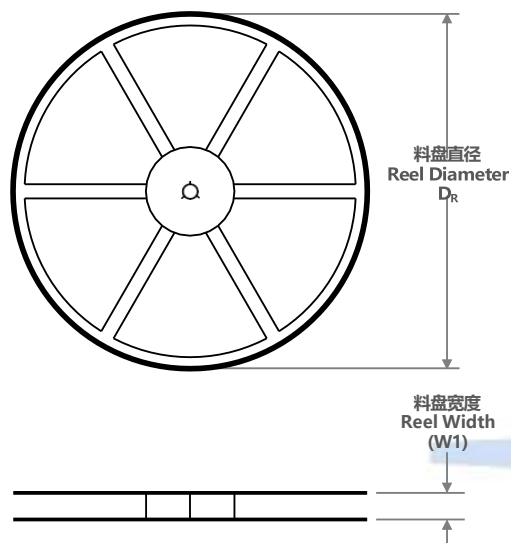
TAPE AND REEL INFORMATION

A0	Dimension designed to accommodate the component width; 料槽宽度
B0	Dimension designed to accommodate the component length; 料槽长度
K0	Dimension designed to accommodate the component thickness; 料槽厚度
W	Overall width of the carrier tape; 载带整体宽度
P1	Pitch between successive cavity centers; 相邻槽中心间距

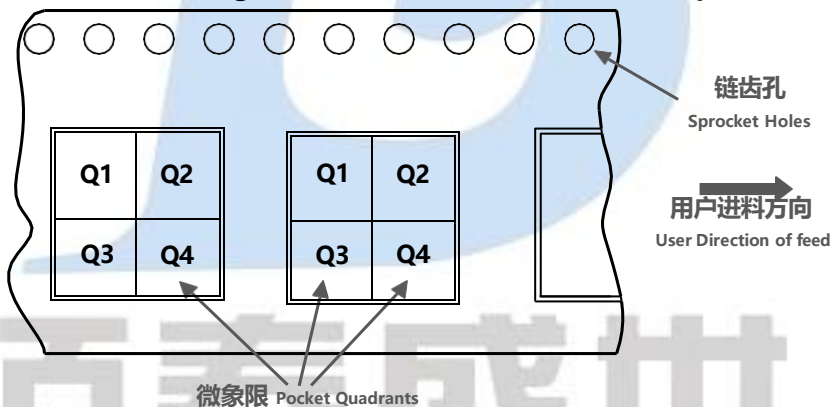
编带 PIN1 方位象限分配
Quadrant Assignments for Pin1 Orientation in Tape

器件料号 Part No.	封装类型 Package Type	封装标识 Package Abbr.	引脚数 Pins	SPQ	料盘直径 D_R (mm)	料盘宽度 W_1 (mm)	A_0 (mm)	B_0 (mm)	K_0 (mm)	P_1 (mm)	W (mm)	Pin1 象限 Quadrant
HTA6861DNER	DFN2×2-8L	DNE	8	3000	179	9	2.25	2.25	0.8	4	8	Q1
HTA6861MSNR	MSOP	MSN	8	5000	TBD	TBD	TBD	TBD	TBD	TBD	TBD	TBD

■ TAPE AND REEL BOX INFORMATION

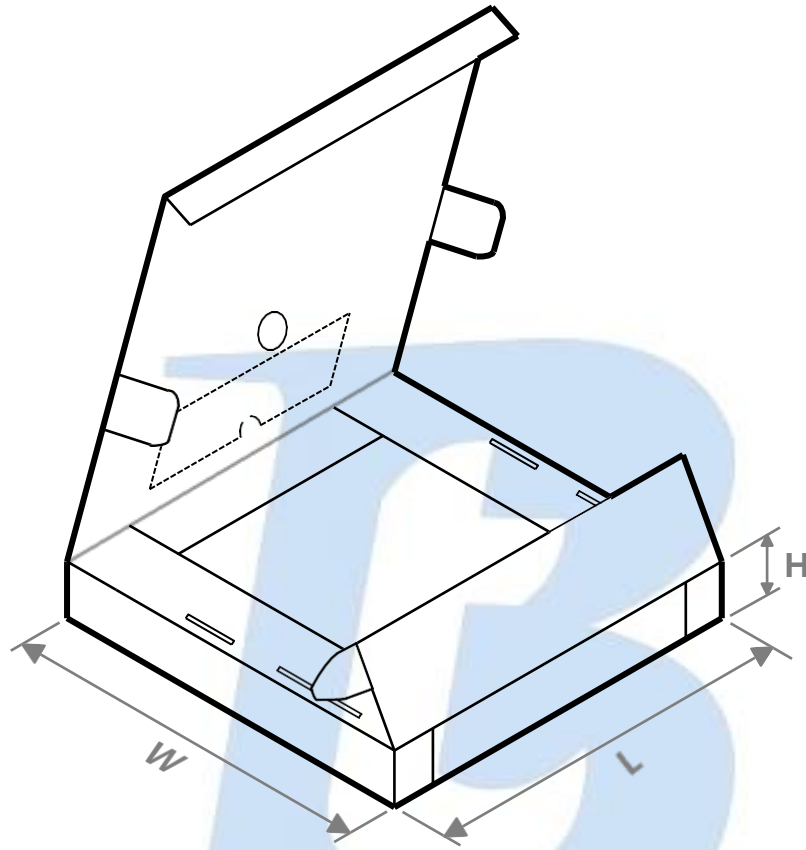

器件料号 Part No.	封装类型 Package Type	封装标识 Package Abbr.	引脚数 Pins	SPQ	长度 Length (mm)	宽度 Width (mm)	高度 Height (mm)
HTA6861DNER	DFN2×2-8L	DNE	8	3000	210	210	210
HTA6861MSNR	MSOP	MSN	8	5000	TBD	TBD	TBD

佰泰盛世
BAITAISHENGSHI

■ **Revision History**

Date	Version	Revision Content
2026-02	V1.0	First version.



IMPORTANT NOTICE

注意

Heroic Electronic Technology (Jiaxing) Co., Ltd (HT) reserves the right to make corrections, modifications, enhancements, improvements, and other changes to its products and services at any time and to discontinue any products or services. Customers should obtain the latest relevant information before placing orders and should verify that such information is current and complete.

禾润电子科技（嘉兴）股份有限公司（以下简称HT）保留对产品、服务、文档的任何修改、更正、提高、改善和其他改变，或停止提供任何产品和服务的权利。客户在下单和生产前应确保所得到的信息是最新、最完整的。

HT assumes no liability for applications assistance or customer product design. Customers are responsible for their products and applications using HT components.

HT对相关应用的说明和协助以及客户产品的板级设计不承担任何责任。

HT products are not authorized for use in safety-critical applications (such as life support devices or systems) where a failure of the HT product would reasonably be expected to affect the safety or effectiveness of that devices or systems.

HT的产品并未授权用于诸如生命维持设备等安全性极高的应用中。

The information included herein is believed to be accurate and reliable. However, HT assumes no responsibility for its use; nor for any infringement of patents or other rights of third parties which may result from its use.

本文中的相关信息是精确和可靠的，但HT并不对其负责，也不对任何可能的专利和第三方权利的侵害负责。

Following are URLs and contacts where you can obtain information or supports on any HT products and application solutions:

下面是可以联系到我公司的相关链接和联系方式：

禾润电子科技（嘉兴）股份有限公司
Heroic Electronic Technology (Jiaxing) Co., Ltd.

地址：浙江省嘉兴市南湖区亚太路906号科创CBD园区21号楼11层
Add: 11th floor, Building 21, No. 906, Yatai Road, Jiaxing, Zhejiang Province
Sales: 0573-82586608, sales@heroic.com.cn
Support: 0573-82586151, support@heroic.com.cn
Website: www.heroic.com.cn; wap.heroic.com.cn
Wechat MP: HEROIC_JX

请及时关注禾润官方微信公众号，随时获取最新产品信息和技术资料！

